

**INSTALLATION INSTRUCTIONS FOR HD V-CAM DOORS
MODELS 8500V & 9500V**

**STEP 1. PREPARATION, PLEASE READ
BEFORE OPENING THIS CARTON:**

Inspect door jamb, making sure it is plumb, square, and structurally sound. Measure opening and compare with opening size on door carton. Door jamb must be a minimum of 4" wide and 1/4" thick or reinforced with steel.

(We do not recommend installation into wood). Open all packages and inspect to ensure everything is included (See parts list page #9). If any parts are missing please report at this time.

**This pair of doors is
manufactured by
National Access Design
to fit an opening size of:**

-----X-----

**INSTALLATION INSTRUCTIONS FOR HD V-CAM DOORS
MODELS 8500V & 9500V**

TOOLS REQUIRED TO INSTALL NAD TRAFFIC DOORS

- *Center Punch*
- *Drill Motor Masonry and Standard*
- *Extension Cord*
- *Hammer*
- *Level*
- *Marker or Pencil*
- *Masking Tape*
- *Phillips Screwdriver*
- *Plumb Bob*
- *Tape Measure*
- *Ratchet Wrench w/ Extension*
- *9/16" Socket*
- *3/16", 1/4", 5/16", 3/8" Drill bits*
- *3/8" Masonry bit*
- *9/16" Wrench*
- *3/8"-16 Tap*



sales@nationalaccessdesign.com

NationalAccessDesign.com

513•351•3400

1871 Summit Road • Cincinnati, Ohio 45237

INSTALLATION INSTRUCTIONS FOR HD V-CAM DOORS MODELS 8500V & 9500V

STEP 2. MOUNTING HOLE LOCATION:

Layout center line from header to floor on steel jambs. Using standard hole pattern (SEE FIGURE #2 on pg. 7) layout, centerpunch, and drill holes using 5/16" drill bit and tap for a 3/8"-16 bolt (provided).

***WELDING HINGE TO THE JAMB IS NOT RECOMMENDED AS THIS PREVENTS ADJUSTMENTS AND CAN CAUSE DAMAGE TO V-CAMS.** Mount V-CAM with appropriate hardware. (SEE FIGURE #3). If masonry or insulated panel, or wood jamb adding a .250" thick steel jamb wrap is recommended.

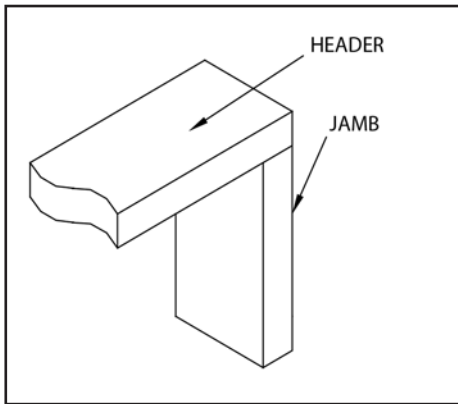

FIGURE #1

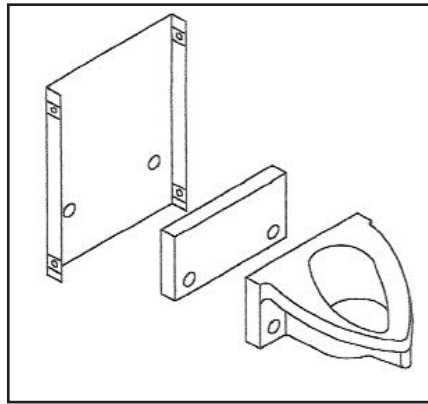

FIGURE #3

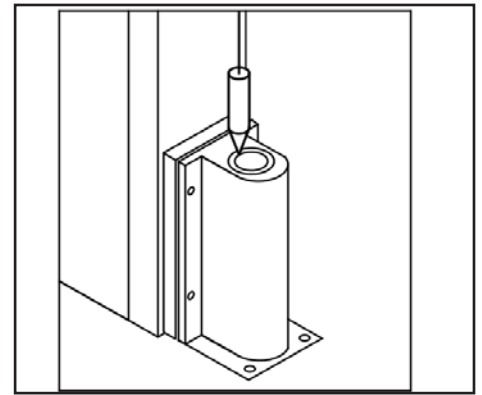

FIGURE #4

Place jamb guard at bottom of door jamb. Use a plumb bob to find location of the bottom hole in relation to the top hole (Center or back edge of each). **(IMPORTANT: NAD DOORS MUST BE PLUMB.** (SEE FIGURE #4). Centerpunch, and drill holes using 5/16" drill bit and tap for a 3/8"-16 bolt (provided). Drill using hammer drill into floor 2 1/2" for floor anchors.

STEP 3. MOUNTING THE DOORS:

Put one bolt into jamb guard and tighten to within 1/4" (SEE FIGURE #5), angle jamb guard as shown). Remove V-CAM from door jamb and slide over top pin on door panel (See FIGURE #6). Insert bottom pin of door into top of jamb guard and stand door upright (FIGURE #7 on page 6). Assemble correct hardware behind V-CAM and bolt snugly. Place a 1 1/2" shim under door to raise it to correct height. If doors are bi-parting repeat all steps.

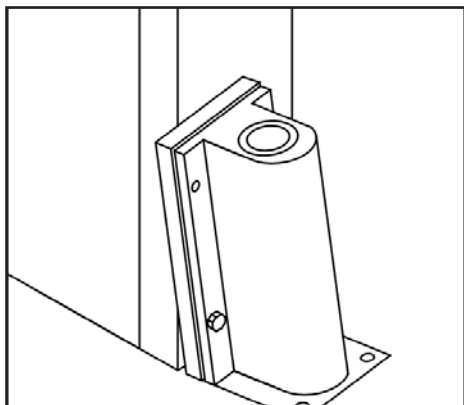

FIGURE #5

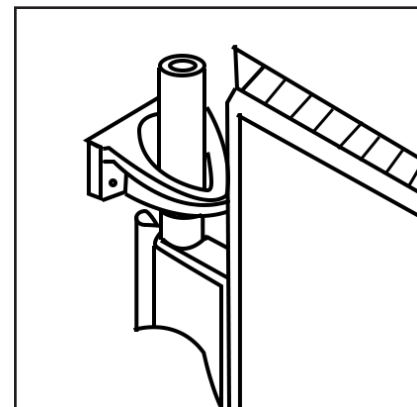

FIGURE #6

INSTALLATION INSTRUCTIONS FOR HD V-CAM DOORS MODELS 8500V & 9500V

STEP 4. ADJUSTING THE PANELS:

Place the Cam Follower over the top shaft of door, align door panel with center of jambs (**Note:** if needed panel can be raised and lowered as necessary to align with header and floor) and snug up the hex screws (FIGURE #8). If bi-parting, repeat this process to other panel. Make adjustments to align both panels to each other and center of the door jamb. Once panel(s) line up tighten hex set screws down as tight as possible. Open both doors to ensure each swings freely, and close completely. Next tighten all remaining bolts as tight as possible. **HEX SET SCREWS ARE TEMPORARY, USED SOLELY FOR THE PURPOSE OF ADJUSTING THE PANEL. THEY WILL LOOSEN OVER TIME. NAD DOORS ARE SUPPLIED WITH 3/8" ROLL PINS THESE MUST BE INSTALLED AT THIS TIME.** After all adjustments have been made, locate the 3/8" guide hole next to the hex set screw on the Cam Follower. Next drill a 1/4" pilot hole all the way through the pin and the other side of the Cam Follower (FIGURE #8). Drill using 3/8" drill bit to open hole to correct diameter. (**Important do not drill 3/8" bit first as this will cause the hole to become oversized**). Align roll pin in hole and drive through both sides of shaft and Cam Follower.

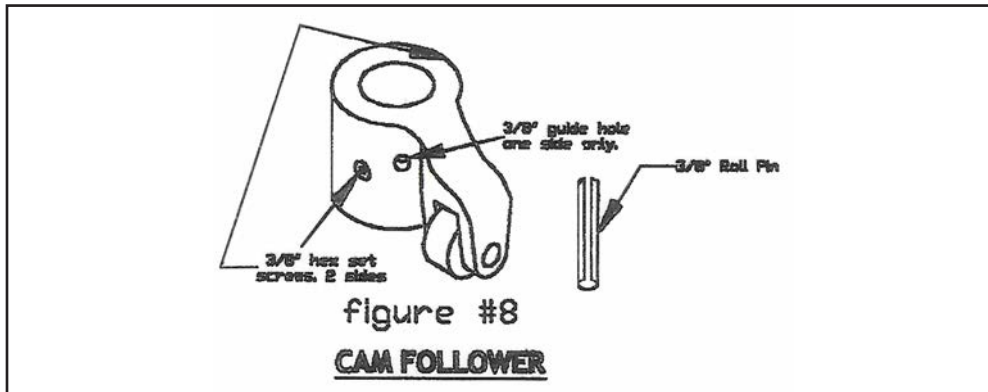

FIGURE #8

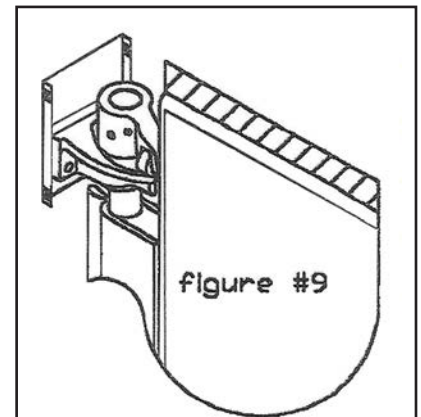

FIGURE #9

STEP 5. FINISH WORK:

At this time V-CAM assembly should resemble FIGURE #9. Lubricate top and bottom shafts with silicone spray or similar light oil. Install Cam Cover on Cam Cover Bracket (FIGURE #10). Cam Cover holes must be field drilled in the Cam Cover (to insure a custom fit) using 3/16" drill bit. Installed properly the top of the Cam Cover will rest on the header and the bottom fringe will overlap the door panel slightly. Remove all protective coverings and clean all surfaces with window cleaner or mild detergent.

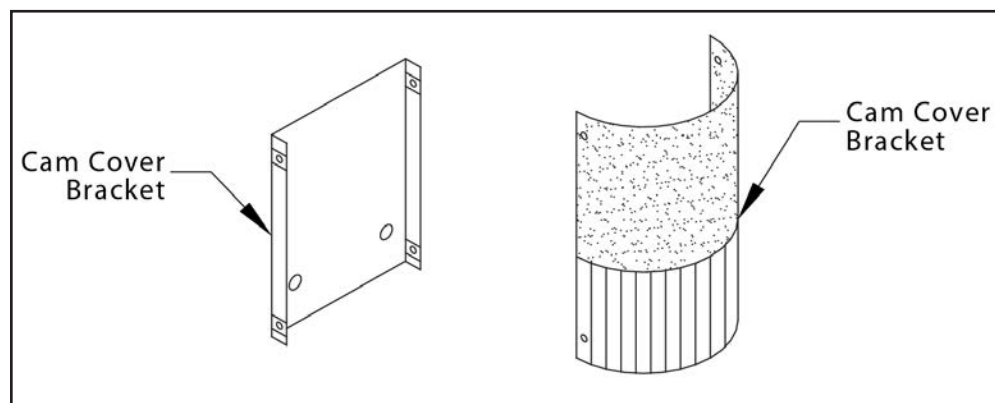

FIGURE #10

INSTALLATION INSTRUCTIONS FOR HD V-CAM DOORS MODELS 8500V & 9500V

STEP 6. MAINTENANCE SCHEDULE:

Clean with mild detergent and vinyl conditioner every 30 days.

Cam Follower should be lubricated every 90 days with silicone spray or light lubricant.

TROUBLE SHOOTING :

PROBLEM: Door will not close properly (slow to come back to center, or sticks open.)

SOLUTION: Check location of bearing in V-Cam. Check that Cam Follower is in correct position. Gasket is dragging on the ground or header; it may need to be trimmed. Door is not plumb. Negative or Positive airflow are affecting the door, may need spring compensator.

PROBLEM: Door will not open completely.

SOLUTION: Check position of Cam Follower when opening as far as possible. It may be rising into the header. Cam Follower may not be aligned with shaft and needs to be lowered. V-Cam may need to be lowered.

PROBLEM: Door worked properly when first installed, but now it is dragging on the ground and won't close.

SOLUTION: Check that roll pin was installed in Cam Follower and door shaft.

**INSTALLATION INSTRUCTIONS FOR HD V-CAM DOORS
MODELS 8500V & 9500V**

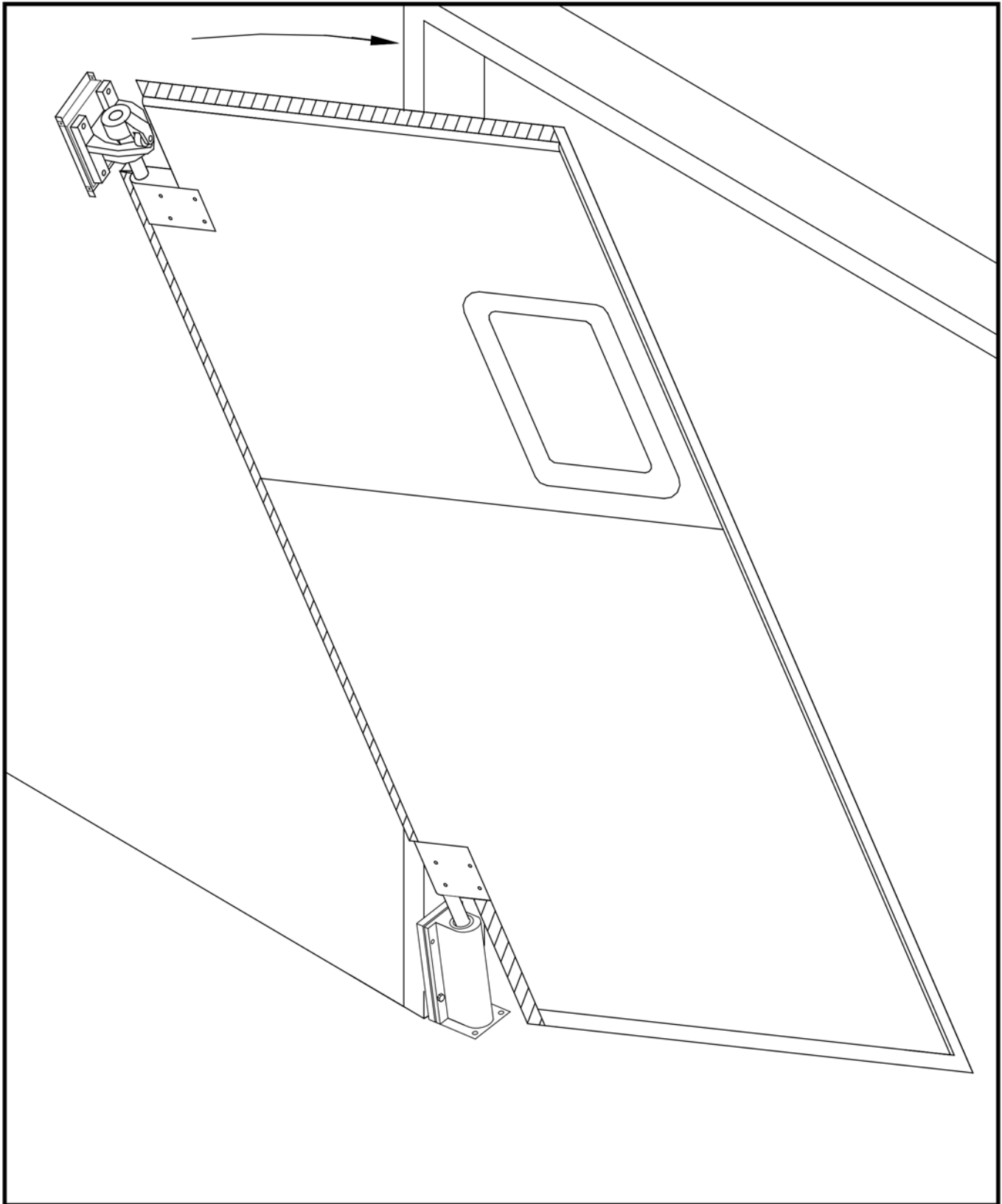

FIGURE #7

DRILL & TAP FOR
.375-16

THIS DRAWING NOT
TO SCALE PATTERN
MUST BE MARKED
OUT ON DOOR JAMB

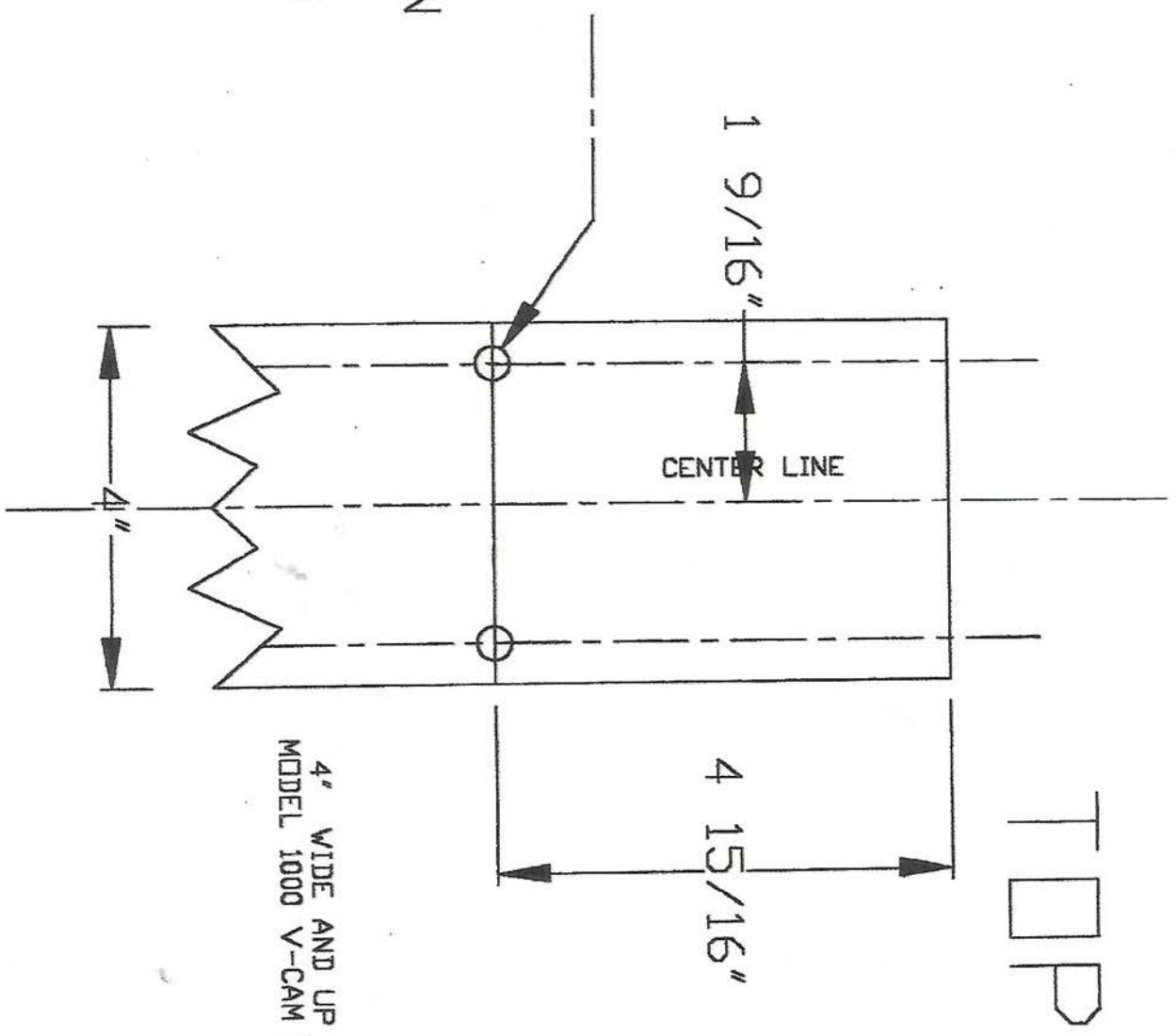
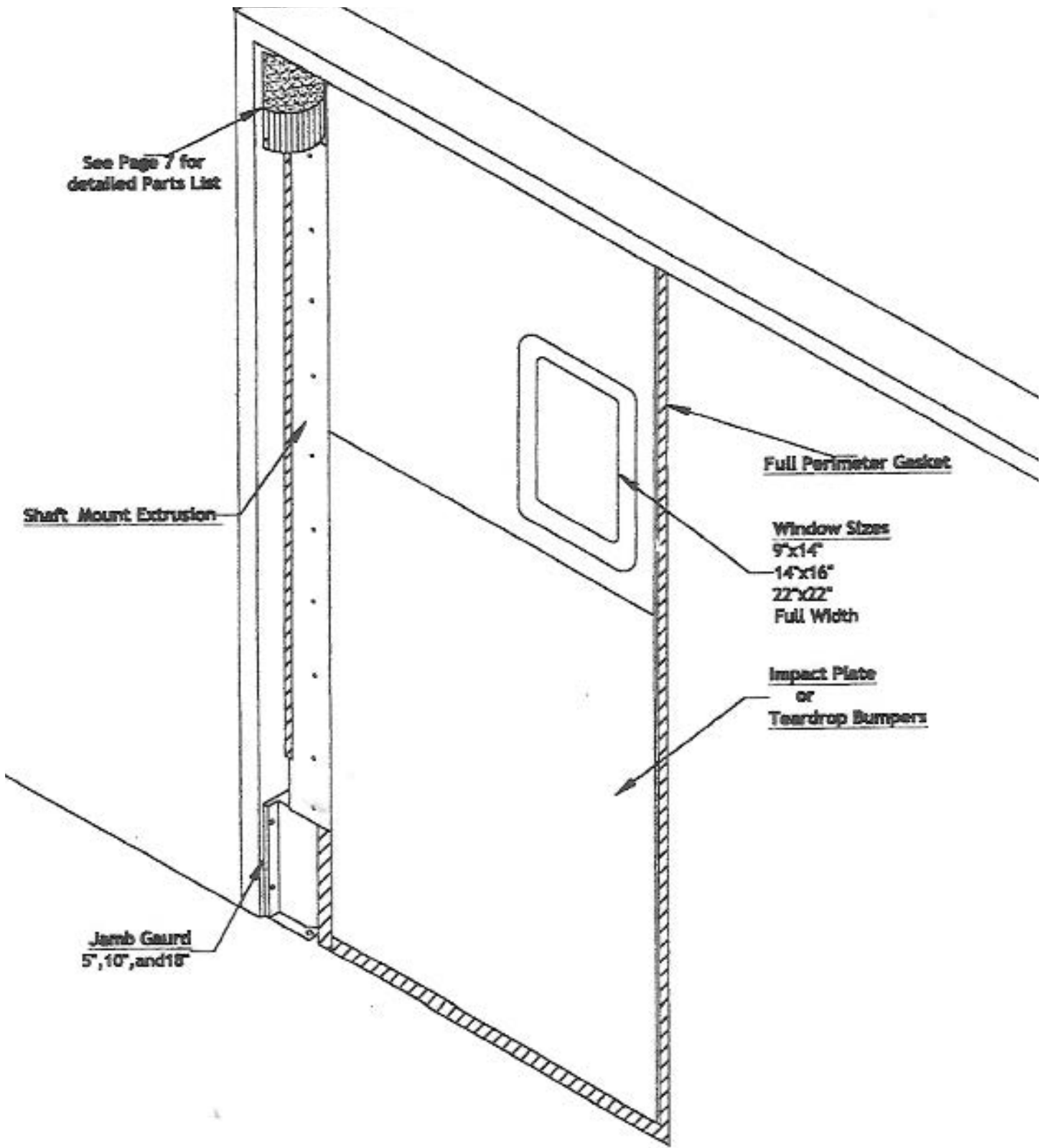
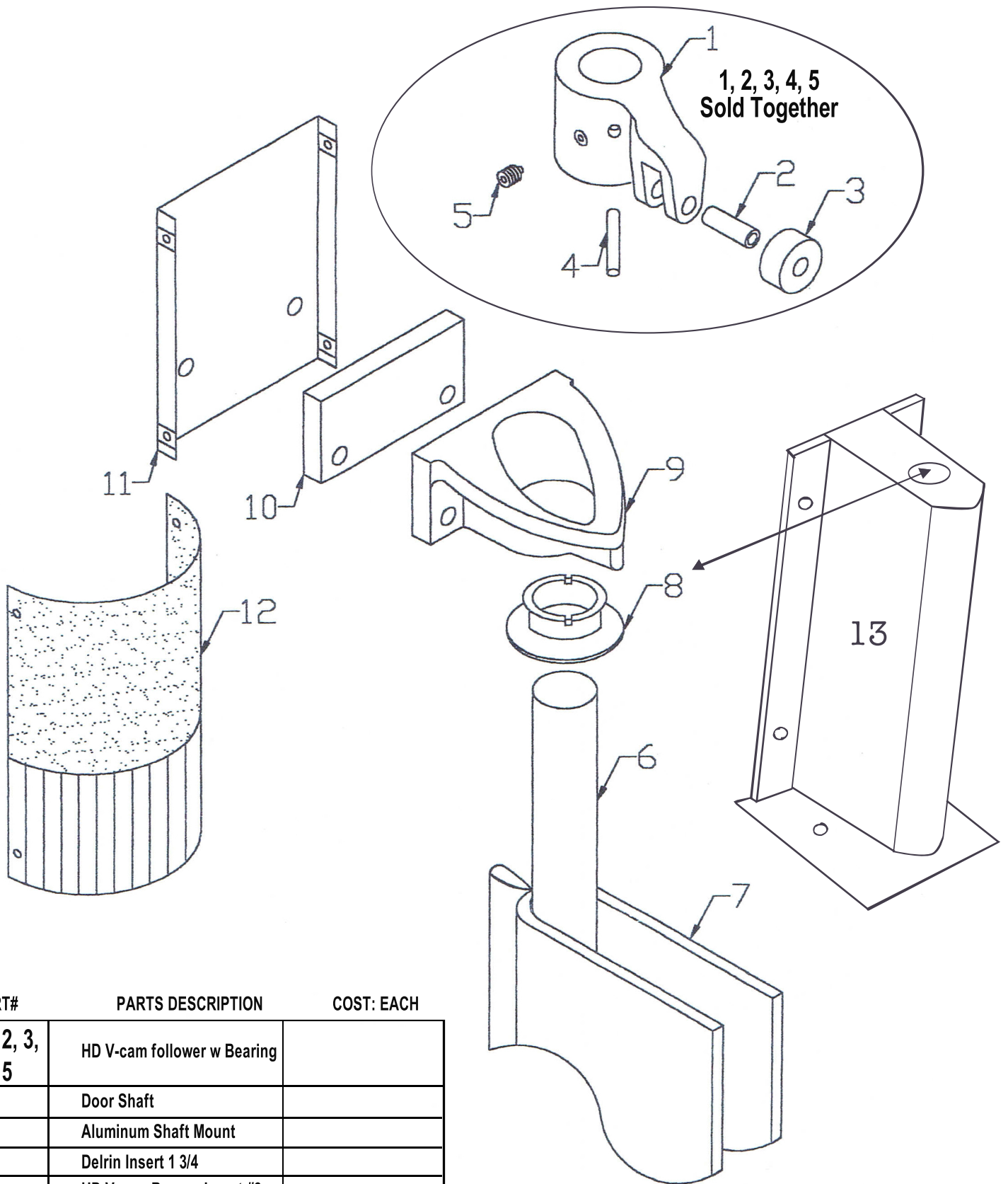

figure #2





PART#	PARTS DESCRIPTION	COST: EACH
1, 2, 3, 4, 5	HD V-cam follower w Bearing	
6	Door Shaft	
7	Aluminum Shaft Mount	
8	Delrin Insert 1 3/4	
9	HD V-cam Base w Insert #8	
10	HDPE Block 2 x 4 x 1/2	
11	Cam Cover Mounting BRKT	
12	Black cam Cover Skirts	
13	HD 10" Jamb Guard w Insert	